

Universal ZIG-ZAG Blanking Station

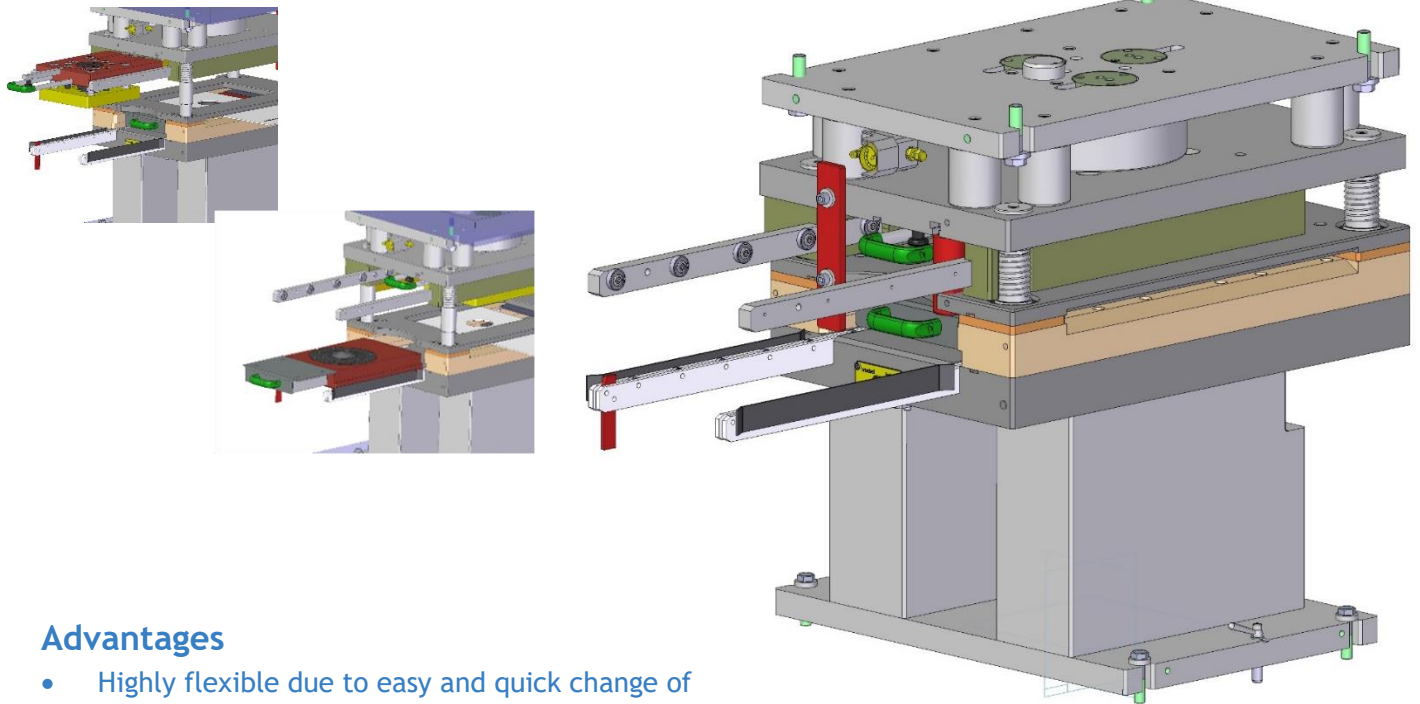

Advantages

- Highly flexible due to easy and quick change of punch die
- Integrated scrap shear for a complete process
- The drawer-based change of dies minimizes tool change times
- High productivity with stroke rates up to 150 SPM
- Safe operations and low error margin due to electrically monitored drawer position
- Low maintenance with quadruple use scrapping knives
- Minimal service with central refilling of nitrogen tank
- Tool change from active parts < 5 min.

Application

- For new and retrofit projects
- Perfect for single ram presses

Options

- Adjustable Scrapping knives
- blank lowerer
- blank feeder
- blank shuttle
- blank loader

Technical Data

Size		PS100	PS200	PS300
Blank diameter	(mm)	60 - 145	100 - 200	200 - 300
Blank pick-up path	(mm)	120	150	350
Strip thickness	(mm)	0,5 - 3	2 - 6	2 - 6
Max. strip pass	(mm)	520	650	1000

The given data are default values and can be customized to the required data.

